

GD Integra

Absolute Integration,
Maximum Reliability



GARDNER
DENVER



Experience Proven Results™

Total Package Design



INT20-INT30
Model EFC

Efficient Airends

Enduro airends are more than reliable. Designed for efficiency over the widest speed range in the industry, Enduro airends make more air using less power than competitive offerings. Thus, with Integra compressors, you can be sure you have minimized the largest cost component of owning a compressor—electrical cost.

Integrated Inside, the Total Package Outside

COMPACT AND SERVICEABLE

With most compressors you get one or the other. Through integration the Integra delivers both. Eliminating unneeded connections and space-consuming piping allows the footprint to be reduced without overlooking ease of servicing. In fact, the serviceability is now better than ever before. Serviceable plus compact. That's Integra.

LOW NOISE AS STANDARD

Every Integra is quiet without expensive adders. Operating from 68 to 75 dBA, Integra compressors can be located anywhere in the work area which means maximum installation flexibility. With top discharge cooling air and a control panel located opposite the fan, Integra compressors sound even quieter than their "official" rating.

A COMPLETE PACKAGE

- Controls that do diagnostics and provide service information – this means ease-of-use while minimizing downtime (see specific one sheet flyer for details).
- Motors with a 5-year warranty as standard.
- Standard moisture separator and drain trap.

ABSOLUTE INTEGRATION, MAXIMUM RELIABILITY

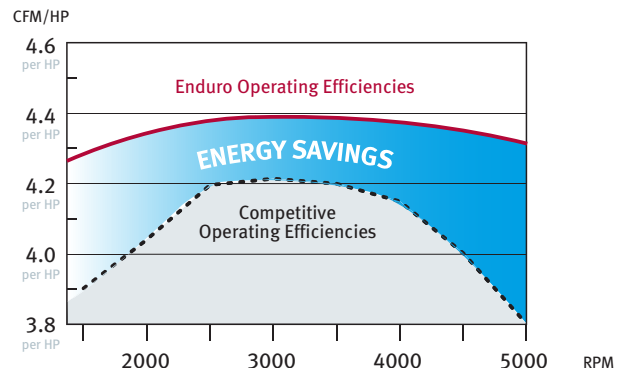

Total Package Design

Never Out of Control

Integra compressors use microprocessor control technology because it's the simplest, yet most powerful compressor control design available. These controllers are built on the foundation of being easy to operate and read, so you just push a button and get back to work. Then if service is necessary or a problem exists with the compressor, the controller communicates the need. With the AirSmart™ controller, you don't waste time troubleshooting or tracking service requirements. Integra controllers are designed to take control!



AirSmart™

AirSmart™ Microprocessor Controller

- Low voltage 24 VDC operation
- Two pressure transducer inputs
- Informative control panel
 - 4 line by 20 character LCD display
 - 4 status LEDs for “at a glance” compressor status
 - 9 buttons for easy control and menu navigation
 - Multiple language support
- The controller is feature rich with maintenance and error handling information including:
 - 29 different sources for advisories
 - 68 different sources for system shutdown
 - Advisory/shutdown history stored in non-volatile memory
 - › Last 6 advisories
 - › Last 6 shutdowns
 - Distributor contact information
- Part number is displayed when consumable item causes advisory or shutdown
- Sequence capability for control of up to eight AirSmart controlled compressors*
- RS-232 serial communications for local monitoring*
- Ethernet communications for remote monitoring*

* With optional communications/sequencer module.

Integrated Advantage

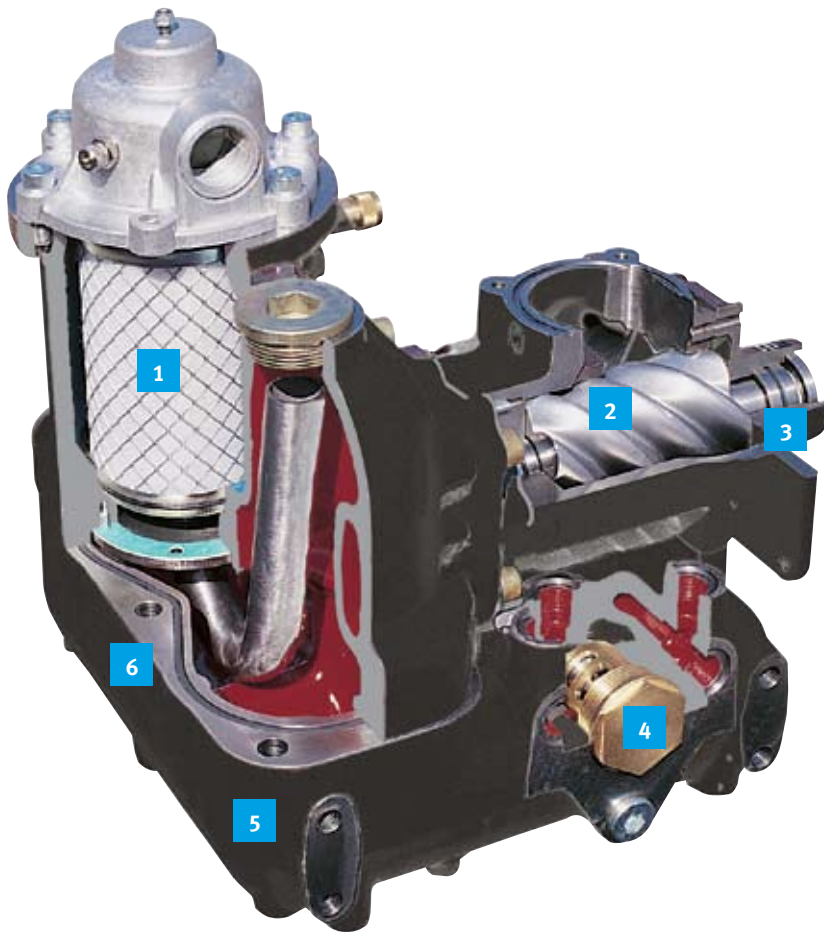

The patented, Integrated advantage is a technological advance in compressor design that drastically reduces the number of traditional connections and fittings to ensure maximum reliability and uptime. A 25-40% reduction in connections comes from combining the lubricant sump, air/lubricant separation system, mixing valve and airend into an integrated component unmatched in the industry. Integrated means you can have a small footprint and serviceability. Best of all, the airend is bolted to the sump for cost effective replacement years down the road. Integrated means unparalleled.

1. THREE STAGE AIR/OIL SEPARATION

- Mechanical redirection
- Cyclone chamber, centrifugal-type air direction
- Pleated filter; inside-out final separation
- The result, less than 2PPM carry over measured before the aftercooler – lowest in the industry

2. ENERGY-SAVING ENDURO AIREND

Lower annual electricity costs – the largest expense associated with compressor operation

3. RELIABLE, CONSISTENT OPERATION VIA NEW GENERATION BEARINGS

Capable of 3 times more load carrying capacity than conventional designs for maximum life

4. INTEGRATED, 3-WAY THERMAL MIXING VALVE

Minimizes leak points through integrated design and ensures maximum lubricant life by prevention of moisture contaminants

5. COMPACT, INTEGRATED DESIGN

Allows for one of the smallest footprints in the industry while maintaining serviceability

6. MAINTENANCE-FREE, LEAK-PROOF OPERATION

O-ring ensures superior sealing for reliability found only in the Integra

Integrated by Design

At the Heart of Integrated Design

Without an efficient, durable airend, a unique compressor design means nothing. That's why Gardner Denver designs and manufactures this critical component in house to exacting standards. Tens of thousands of Enduro airends are in operation worldwide, proving that the heart of the Integra series can stand the test of time.

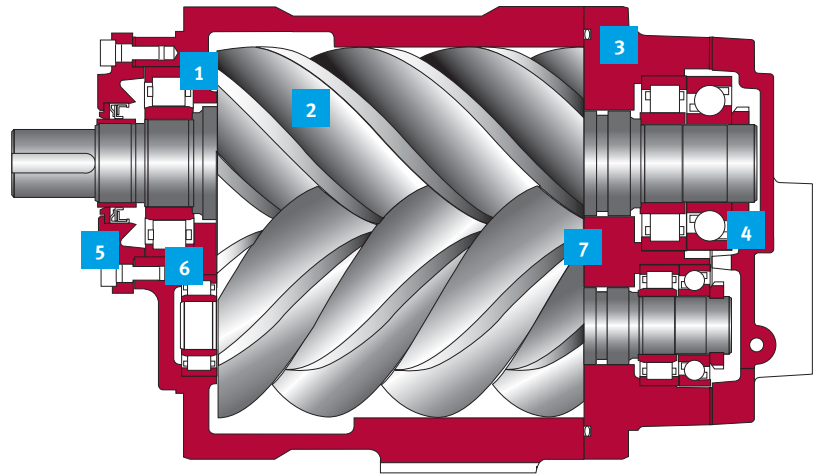

1. INTEGRAL HOUSING

Fewer Parts results in less opportunity for leaks to develop

2. ADVANCED ROTOR PROFILE

Shortened Sealing line and minimal air "slippage" yield maximum compressor efficiency

3. O-RING SEAL

Highest quality positive sealing for leak free operation

4. DEDICATED THRUST BEARINGS

Provide total support of gas loads to ensure optimum running clearances at every operating condition

5. MULTI-LIP SHAFT SEAL

Keeps the lubricant in and the dirt out for maximum seal performance and life

6. HEAVY DUTY INLET BEARINGS

Oversized to achieve maximum bearing life and rotor stability

7. MINIMIZED BLOW HOLE

High efficiency profile minimizes internal losses associated with blowback

Integrated by Design

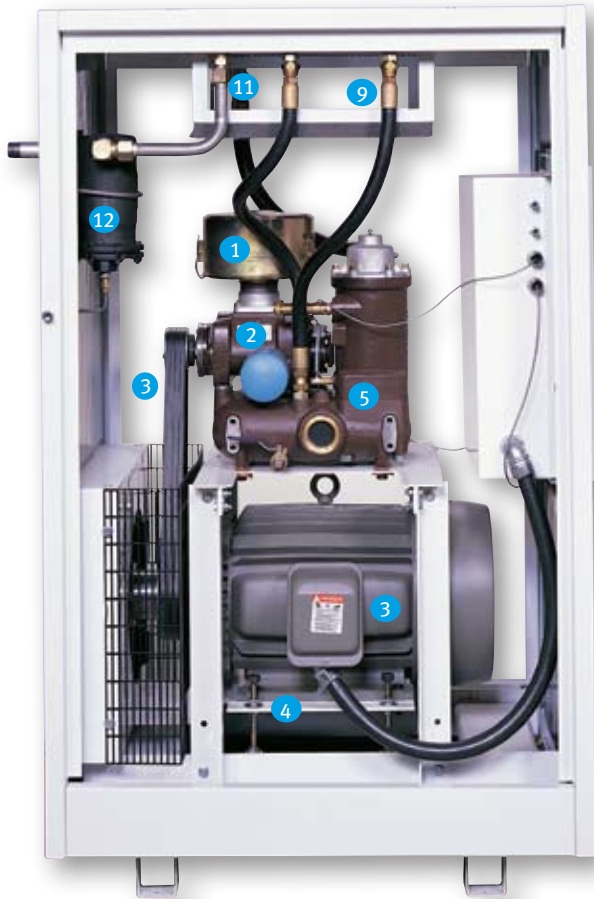

1. Air is drawn through an inlet air filter
2. into the air end, and oil is injected between the rotors.
3. The air end is rotated with belts driven by an electric motor. Motors come with a standard 5 year warranty!
4. The adjustment of belt tension through a motor mounting plate is quick and easy.
5. From the air end, the air-oil mixture flows into the unit, where three-stage separation takes place. The first stage is carried out by a baffle in the oil sump directly after the air end.
6. The second is the intelligent cyclone stage
7. and the final is carried out by the separation elements.
8. Separated oil remains on the bottom of the module unit, where the thermostat valve
9. passes it through the oil-cooler
10. or directly to the oil filter, depending on the temperature. The oil then returns to the air end.
11. Clean compressed air flows into the after cooler, where water is separated through condensation.
12. The condensate is automatically removed in the water separator.

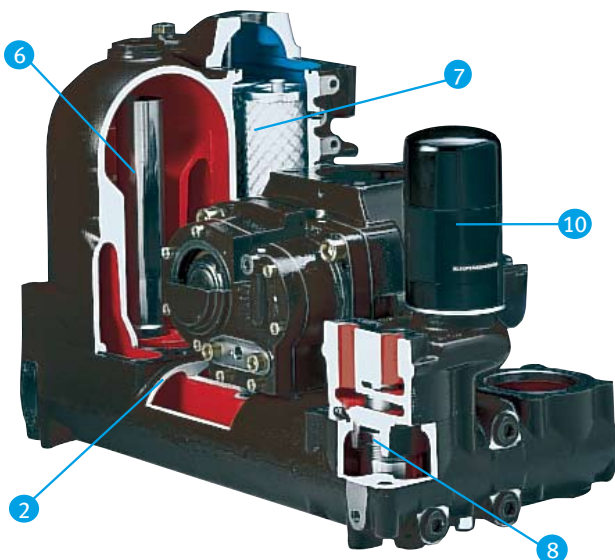

Integra compressors are fully automatic and deliver air on demand. When air consumption ceases, the compressor switches to no-load. If there is no demand for compressed air, the compressor stops automatically until air is needed again. This maximizes compressor efficiency and reduces operating costs.

Gardner Denver's exclusive integrated air end design delivers both small footprint and serviceability in one!

Loaded with Options

Integra 20–50 HP Standard Equipment

- Integrated, Single-Stage Rotary Screw Air Compressor with Load/No Load Control
- 3 Phase, 60 Hertz, 1.15 Service Factor, EPAct Energy Efficient, Open Drip Proof Drive Motor includes 5 year warranty-standard
- Small, Compact Footprint
- Standard 75 dBA Quiet Sound Enclosure
- Adjustable Motor Base
- Package Mounted Moisture Separator/Trap
- Radiator-Type Oil Cooler and Aftercooler
- OSHA Approved Drive Guard
- Spin-On Type Full Flow Oil Filter
- Easy Access Service Points Through Removable Door Panels
- Factory Fill AEON® 4000 Rotary Screw Lubricant
- Heavy-Duty Inlet Air Filter
- Thermal Mixing Valve for Oil Temperature Control
- Corrosion Resistant Control Line Tubing
- Air/Oil Reservoir Pressure Relief Valve
- Minimum Discharge Pressure/Check Valve
- Automatic Blowdown Timer
- NEMA 4 Control Enclosure
 - Mounted and Wired Full-Voltage Magnetic Motor Starter
 - Control Voltage Transformer
 - Emergency Stop Button
- Control Cable Kit
- CSA Labeled and Approved Electrical Controls and Wiring

- AirSmart microprocessor controller
 - Low voltage 24 VDC operation
 - Two pressure transducer inputs
 - Sequence capability for control of up to eight AirSmart controlled compressors
 - RS-232 Serial communications for local monitoring (4)
 - Ethernet communications for remote monitoring (4)

Optional Equipment

- AEON® 9000SP Rotary Screw Lubricant
- AEON® 9000TH High Temperature Lubricant
- AEON® 6000FG Food Grade Lubricant
- AEON® 6000FG-68 High Temperature Food Grade Lubricant
- TEFC Drive Motor
- ODP or TEFC Premium Efficiency Drive Motor
- Wye Delta Motor/Starter
- Communication/Sequencing Module



Other Innovative Products



FIL Series High Efficiency Filters

A full range of filters 20–21,250 cfm; coalescing, particulate, and activated carbon for the removal of water, oil, and particulates from compressed air.



DS2 Series Evacuator Drain Valves

A full family of zero air loss, energy efficient demand drains. Ruggedly designed to effectively and reliably prevent moisture damage to dryers, air tools, gauges, and other critical components.



RNC Series Refrigerated Dryers

A full line of high quality refrigerated dryers with features and benefits unmatched by the competition. Designed to produce dew points as low as 38°F in compressed air.



DGH Series Desiccant Dryers

A complete line of desiccant dryers for the removal of water vapor in compressed air to dew points as low as -100°F.

Gardner Denver®



Please recycle after use.

Member



www.GardnerDenverProducts.com maggie@gardnerdenver.com

Gardner Denver, Inc. 1800 Gardner Expressway, Quincy, IL 62305

Customer Service Department

Telephone: (800) 682-9868 FAX: (217) 224-7814

©2009 Gardner Denver, Inc. Litho in U.S.A. GS-INT-FAM 1st Ed. 4/09
Supersedes 13-15-210 3rd Ed. 1/07